

DATASHEET:

RTB 50 PHOENIX

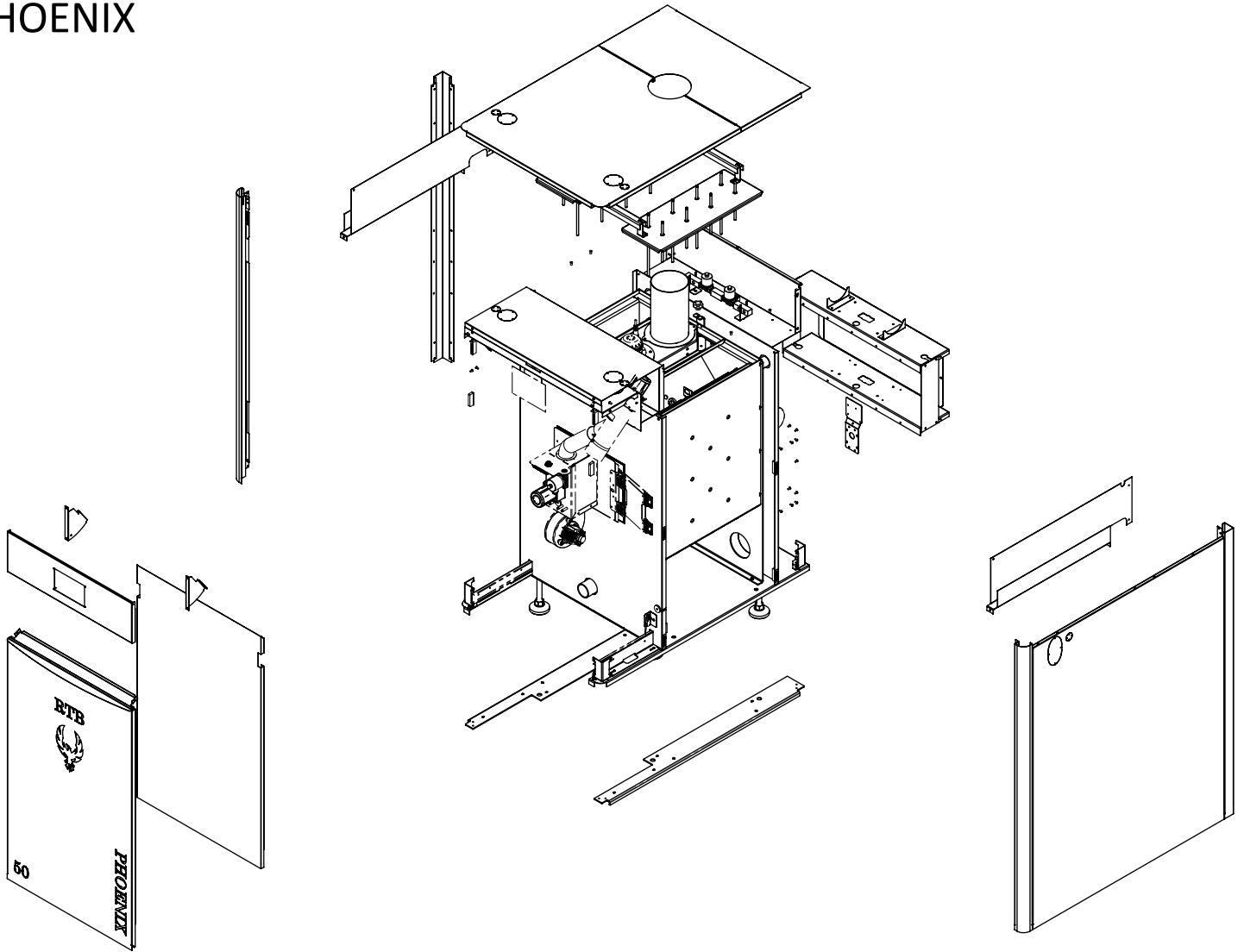



DATASHEET:

RTB 50

PHOENIX

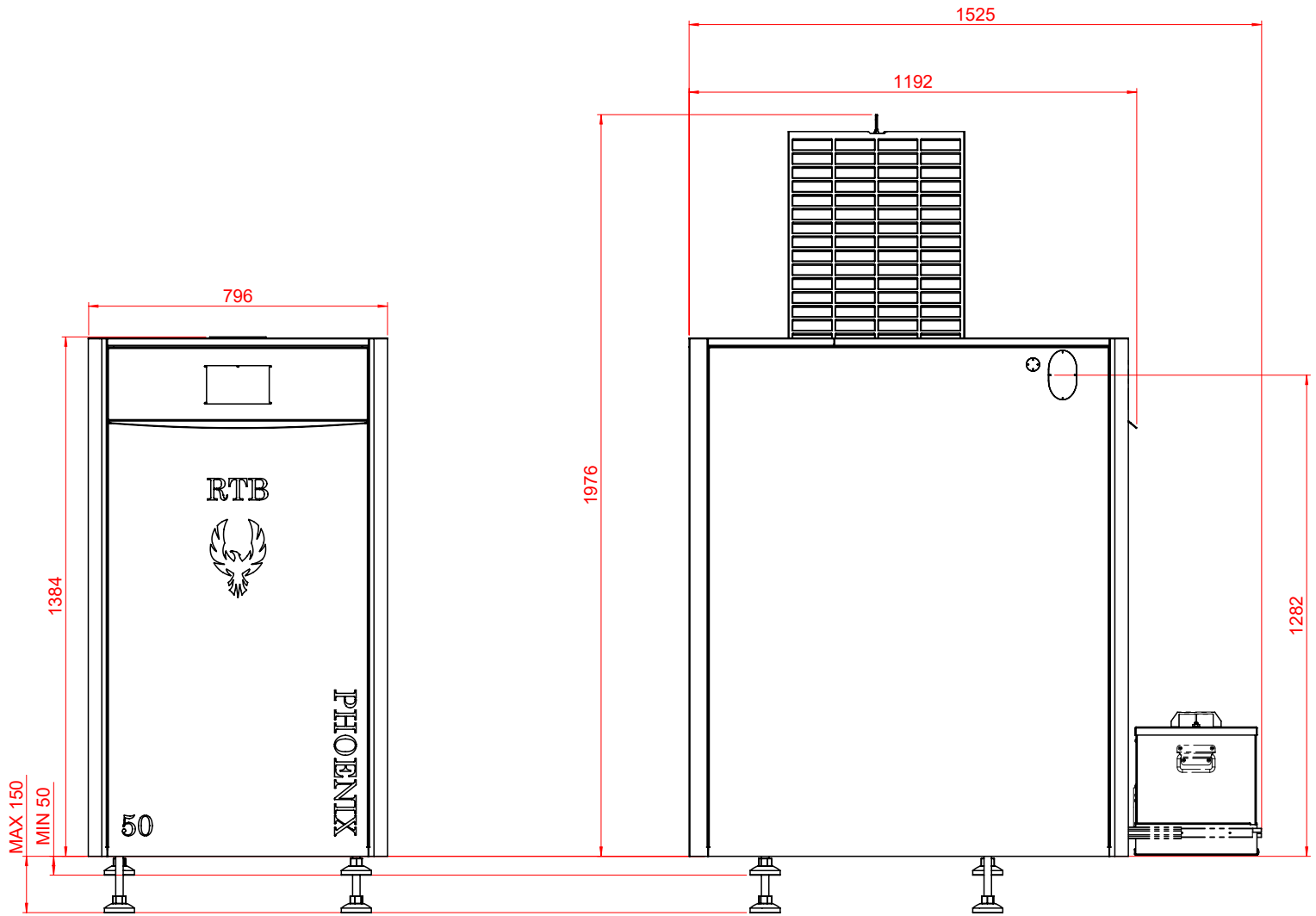

DATASHEET:

RTB 50

PHOENIX

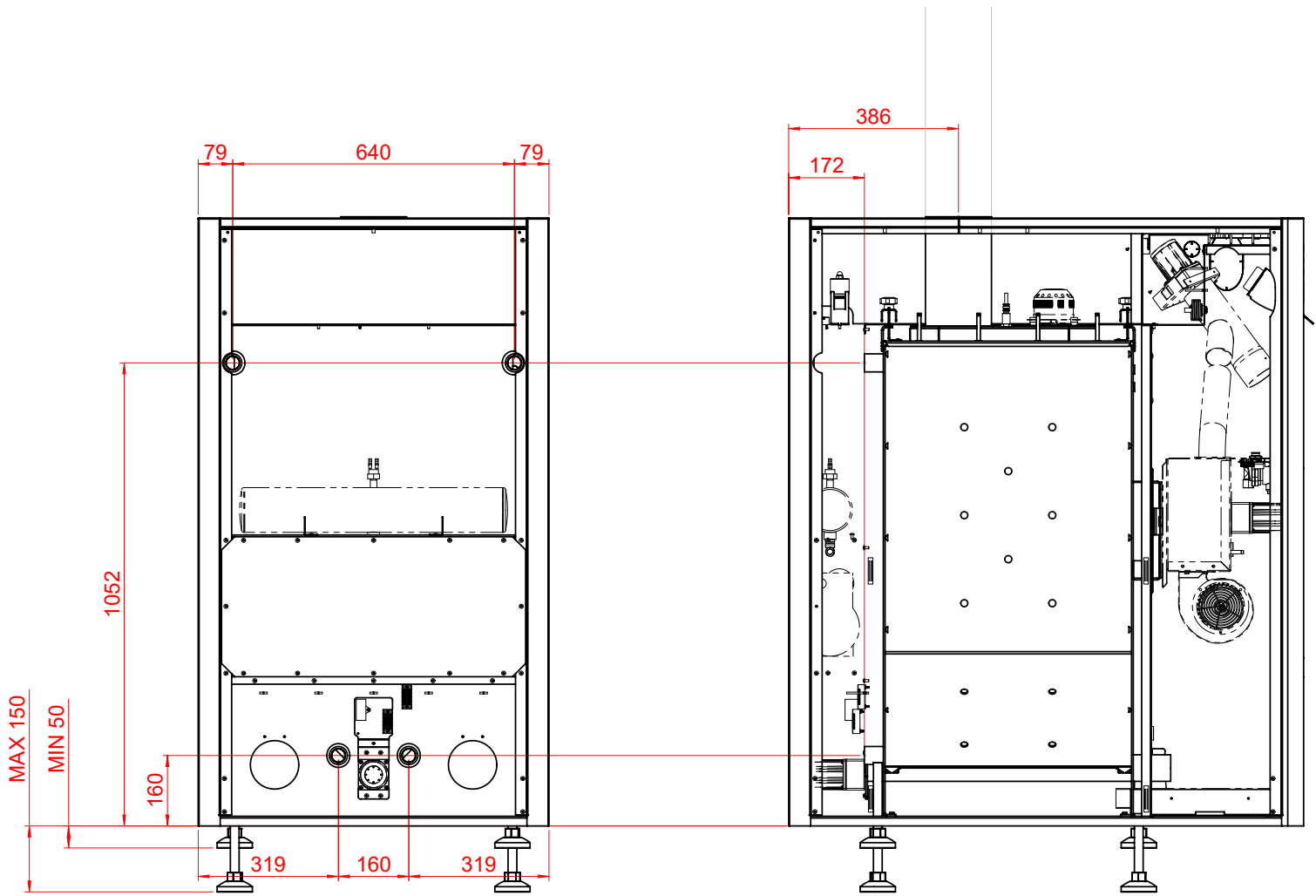



DATASHEET:

RTB 50 PHOENIX

Product Name	RTB 50
SKU	90135000
Output (kW)	14.33 - 46.83 kW
Design Model	Phoenix
Efficiency Nominal Output	93,60%
Efficiency Low Output	94,60%
EN303-5:2012 Class	5
EN303-5:2012 Test rapport	300-ELAB-2179
Controller:	V16
Width, only Boiler (mm)	796
Depth (mm)	1192
Height, only Boiler (mm)	1434 -1534
Chimney (mm)	150
Weight (Kg)	470
Water Volume (L)	78
Ash Tray Size (L)	60
Output / Return / Filling	1"
Exhaust fan	Included
StokerCloud Monitoring	3 years included
Mobile Phone APP via stokercloud	3 years included
Update Via Internet	3 years included
Weather Compensation	*
Smoke Temperature Sensor	Included
Pump Control Function	Included
Timer Function	Included
E-mail Notification on Alarm	3 years included
SMS Notification on Alarm	*
Hot Water Priority	*
Water Flow Sensor	*
Return Temperature Sensor	*
Outdoor Temperature Sensor	*
Vacuum Transport System	*
Oxygen Control	Included
Compressor Cleaning Boiler	Included
Compressor Cleaning Burner	Included
Low Noise Compressor	Included
Compressor Control Function	Included
Ash Removal	Included
Ash Compression	Included
Ash Drawer	Included
Lazer Distance Sensor (pellet level monitoring)	Included
Under Pressure Sensor	Included
Air Flow Sensor	Included
Back Pressure Sensor	Included
* Exstra accessories required	